

# **HZJD-2 Insulating Oil Dielectric Loss And Resistivity Tester**

**Huazheng Electric Manufacturing(Baoding) Co., Ltd**



## Contents

I.Overview .....	1
II. Key Function And Feature .....	1
III. Major Technical Indicators .....	2
IV.Use Conditions .....	3
V.Panel Description And Operation Notice .....	3
VI.Operation Approach .....	5
VII.Instrument Verification .....	10
VIII.Introduction To The Test Cell .....	12
IX.Common Problems .....	17
X. Packing List .....	17



## I. Overview

The Insulating Oil Dielectric Loss and Electrical Resistivity Tester is based on the national standard GB/T5654-2007, 《Liquid insulating material of relative permittivity, dielectric loss factor and DC resistivity measurements》 and mainly used for measuring the dielectric loss factor and DC resistivity of liquid medium, such as insulation oil. Etc. The instrument is characterized by integrated structure, and integrates the dielectric loss of test cell, temperature controller, temperature sensor, dielectric loss test bridge, AC test power, standard capacitor, high resistance meter, DC high voltage source and other major components. The instrument adopts full digital technology and all of the intelligent automatic measurement, is equipped with large screen (240\*128) LCD display with full Chinese menu, which each step has prompted the Chinese, the test results can be automatically stored and printed output, so that the operator without professional training will be able to use it proficiently.

## II. Key Function And Feature

1. The test cell used three-electrode-type structure in accordance with the national standard of GB/T5654-2007, with electrode gap 2mm, can eliminate the effect of stray capacitance and reducing leakage on the dielectric loss test results.
2. Instruments used medium frequency induction heating, PID temperature control algorithm. The heating method can make the test cell and heated without contact, and uniform heating, fast, convenient control, and make the temperature strictly controlled within the preset temperature range.
3. Internal capacitor is SF<sub>6</sub> gas-filled three-electrode capacitance, its dielectric loss and capacitance is not affected by the ambient temperature and humidity. It can make the instrument accuracy be guaranteed after prolonged use.
4. AC test power supply using AC-DC-AC conversion, effectively avoid the fluctuations in mains voltage and frequency on dielectric loss measurement accuracy effect. Even a generator, the instrument can work properly.
5. Perfect protection function; When there is over voltage、over current or high-voltage short circuit, instruments can quickly cut off pressure, and issues a warning message. When the temperature of the sensor failure or not connected, the instrument will also issue a warning message.  
There is a temperature limiting relay in the medium frequency induction heating furnace. When temperature above 120 degrees, the instrument frees the relay and stops heating.
6. More convenient the experimental parameter is set. Temperature setting



range 0~125°C, AC voltage setting range 500~2200V, DC voltage setting range 0~500V.

7.Large LCD display with backlight and clear display, Friendly human-machine interface, simply follow the Chinese characters menu prompt, enter the command, the instrument can be automatically tested, and automatically store and print test results.

8.The instrument comes with real time clock, the test date and time can be saved、displayed and printed with the test results.

9.Test cell calibration. We can judge the test cell's cleaning and assembly by measuring electrode capacitance and dielectric loss factor of the test cell. The calibration data is automatically stored, in order to accurately calculate the relative permittivity and the DC resistivity.

### III. Major Technical Indicators

Voltage supply: AC220V±10%

Power frequency: 50Hz/60Hz ±1%

Measuring range:

Electric capacity 5pF~200pF

Relative permittivity 1.000~30.000

Dielectric loss factor 0.00001~100

DC Resistivity 2.5MΩm~20TΩm

Measuring accuracy:

Electric capacity ± (1% of measuring value+0.5pF)

Relative permittivity ±1% of measuring value

Dielectric dissipation factor ± (1% of measuring value+0.0001)

DC Resistivity ±10% of measuring value

Resolution:

Electric capacity 0.01pF

Relative permittivity 0.001

Dielectric dissipation factor 0.00001

Test temperature:0~125°C

Error of measurement:±0.5°C

Test Voltage AC(RMS):500~2200V Continuously adjustable, frequency 50Hz

Test Voltage DC: 0~500V Continuously adjustable

Power: 100W

Overall dimension:500×360×420

Total weight: 22Kg



## IV. Use Conditions

Ambient temperature: 0°C~40°C

Relative humidity(RH): <75%

## V. Panel Description And Operation Notice

### 1. Panel Description:

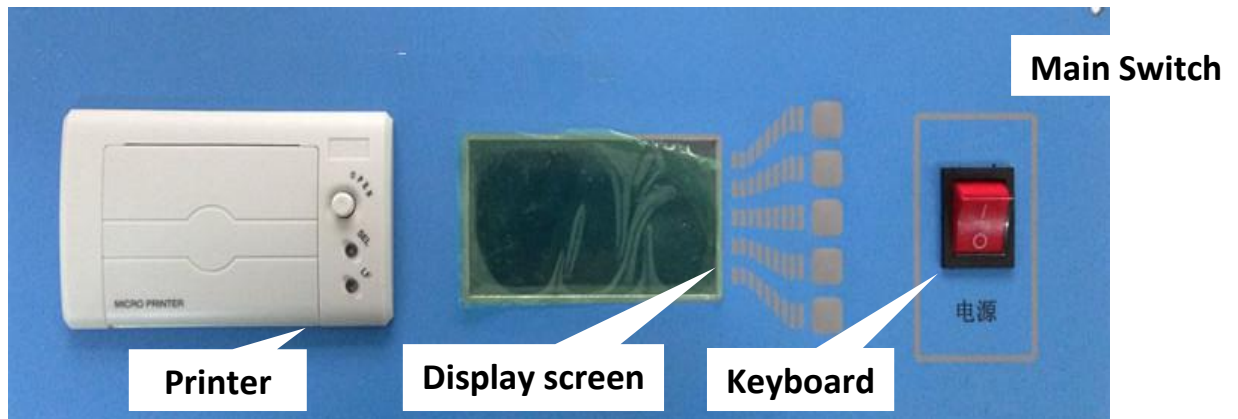

Figure 1 Operating Panel

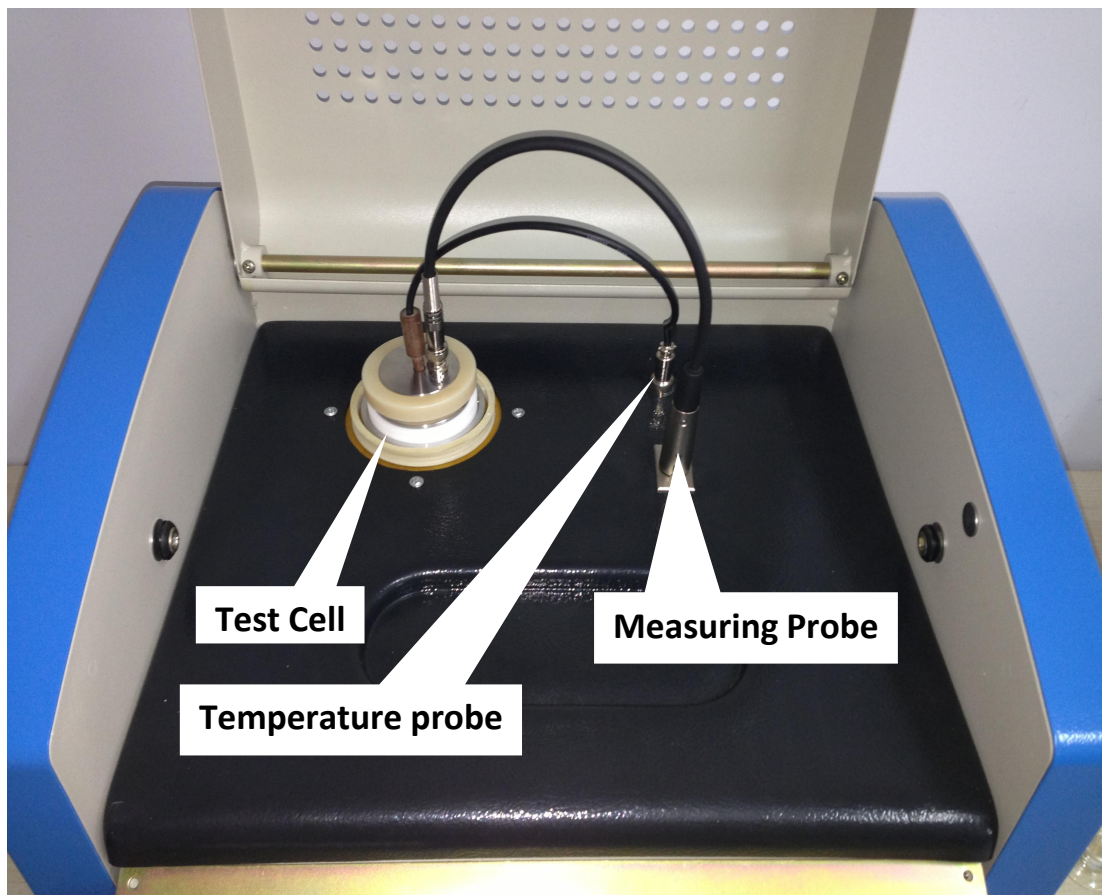
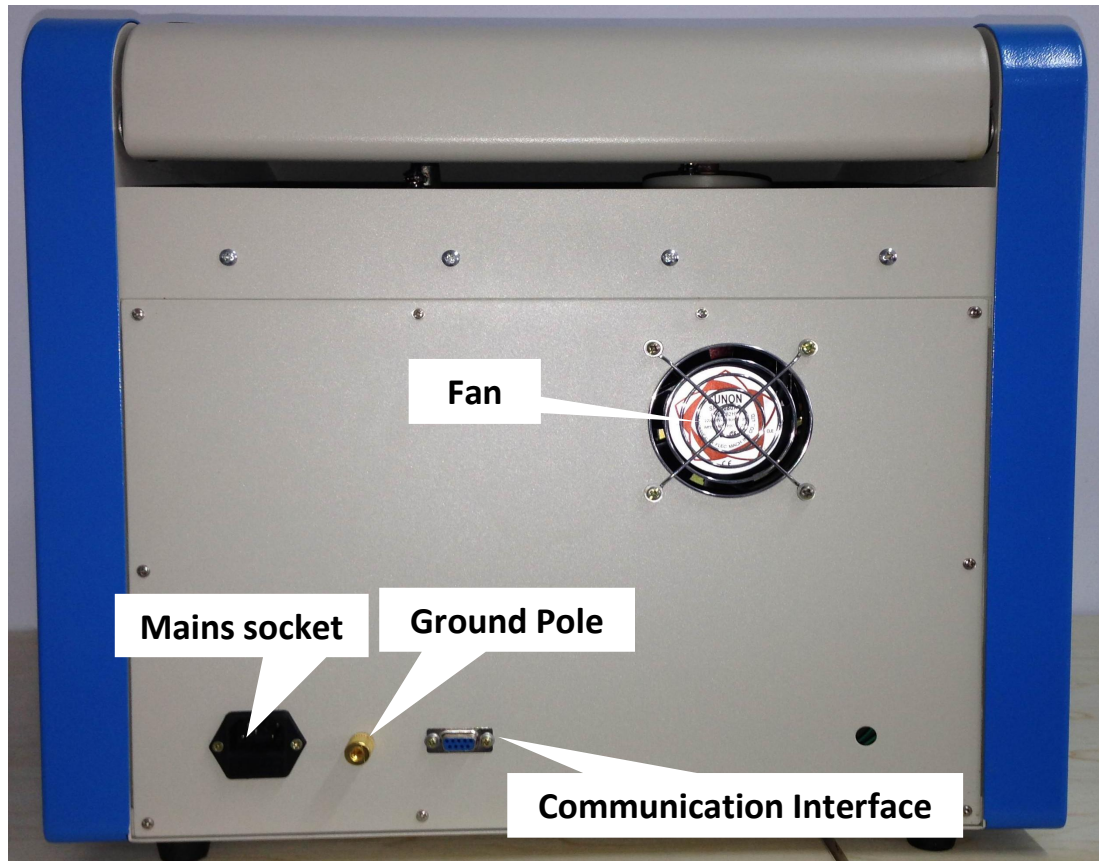

Figure 2 Top Panel



**Figure 3 Back Panel**

## 2. Instrument instructions and matters needing attention

- (1) Be sure to connect the ground cord firmly before start up the equipment, and switch on AC220V power supply.
- (2) Open protective cover, and take out the test cell; We should shut the protective cover, when heating and testing the dielectric loss.
- (3) The cover is protective and when you open it, will interrupt the heating and high pressure.
- (4) During the test, there is high pressure and high temperature. Do not contact the test cell and cable when the power is on and testing.
- (5) Be careful so as not to sprinkle oil into the test cell receptacle and the side panel when injecting and discharging oil.
- (6) If there was a crash test, turn the system back on, **restart** the instrument.

### **Use the appropriate power supply cables.**

Only use the product-specific power supply line in accordance with the product specification. Be right to disconnect and connect.

**The instrument must be adequately grounded.**



In addition to the power line grounding conductor grounding, product shell's grounding columns must be grounded

In order to prevent electric shock, the grounding conductor must be connected with the ground.

Before connecting with the input or output terminals of the product, make sure that the product is properly grounded.

**Note that rating value of all terminals.**

To prevent fire or electric shock hazard, please note that all rating values and markings in the product.

Before connecting this product, please read the product manual in order to further understand the information about rating values.

**Use the appropriate fuse.**

Use only the fuse in accordance with provisions of this product type and rating.

Do not operate when there is any suspicion of failure. If you suspect this product is damaged, please contact our repair staff to check, and do not continue the boot operation.

**Align the locating slot when the internal electrode into the external electrode.**

Do not operate in humid environments.

Do not operate in explosive environments.

Keep the surface clean and dry.

**Special notice:** This instrument has high voltage output, improper use can compromise personal safety, prior to the use of this instrument, be sure to read the instruction manual carefully!

## VI.Operation Approach

1.Place the cleaned test cell on the socket, and connect the test cable as shown in Figure2.

2.Start the instrument.

Turn on the power switch, and the LCD displays the main menu as shown in Figure 4.

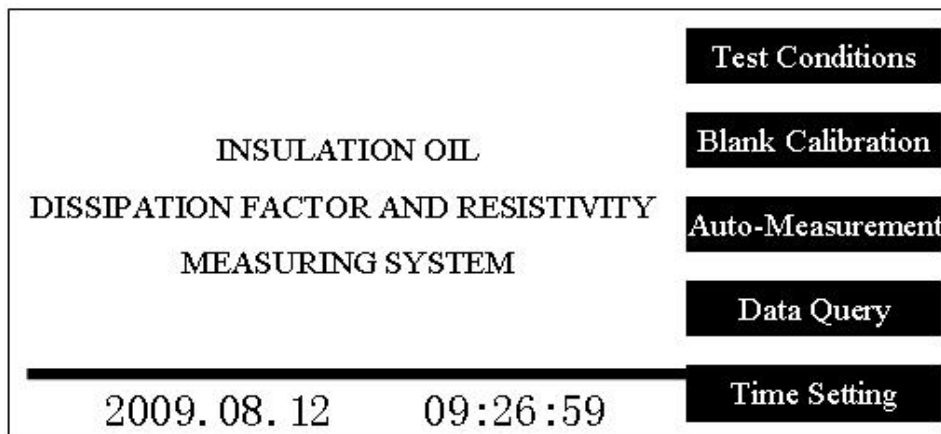

**Figure 4****3. Test Conditions**

Enter “Test Conditions” parameter settings screen as shown in Figure 5.

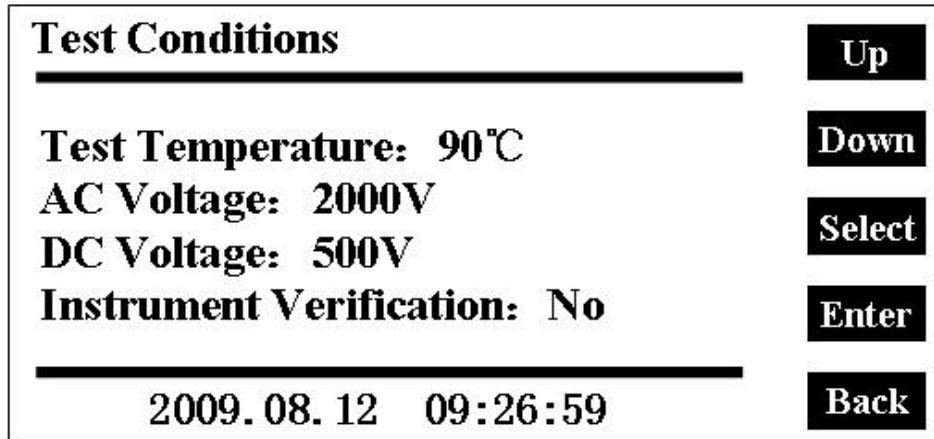
**Figure 5**

① Parameter range: Temperature:0~125°C

AC Voltage:500~2200V

DC Voltage:0~500V

Instrument Calibration:Yes or No

② Parameter setting method

Press “Select” key and position flashing cursor on the parameter to be set.

Press “Up” or “Down” key to do the cycling settings.

Press “Enter” or “Back” key, the instrument save the setting parameter, and return to the main menu.

③ Instrument Verification

The resistivity and dielectric loss can be measured in the absence of heat and with opening the lid of instrument, when the ‘Instrument Verification’ was set to ‘Yes’. It was generally used in verifying the instrument. (See ‘VII.Instrument Verification’)

**4. Test cell calibration**

Prior to entering the calibration, make sure that no oil in the test cell and connect the test cable and temperature probe cable.

Press “Blank calibration” key, and go to the empty cup calibration screen as shown in Figure 6.

In Fig.6-1, press “Enter” key during the process of warming, and it will boost under the current temperature.

In Fig.6-2, press “Enter” key during the process of boosting, and it will do the test under the current voltage.

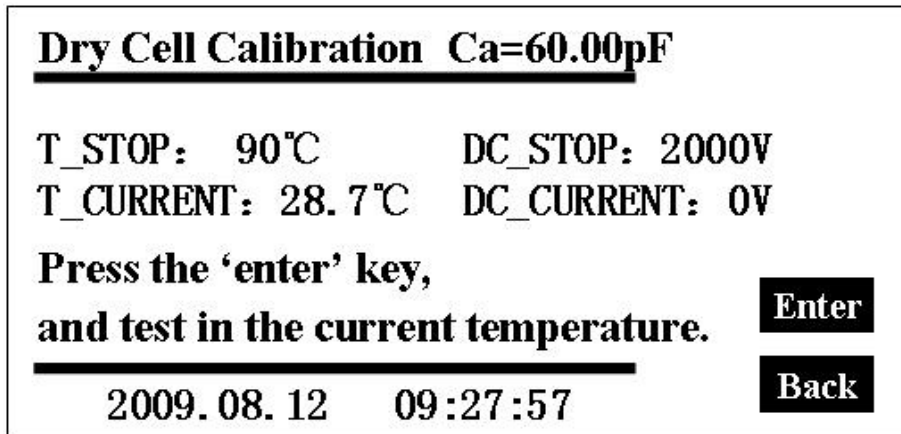

Figure 6-1

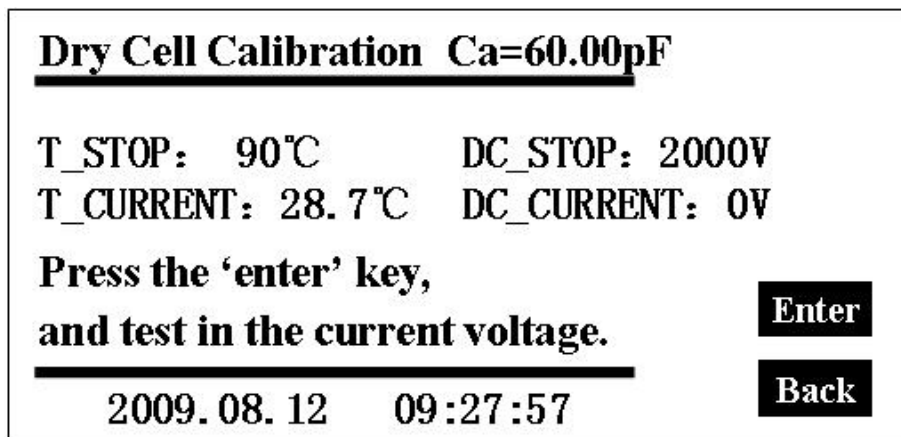
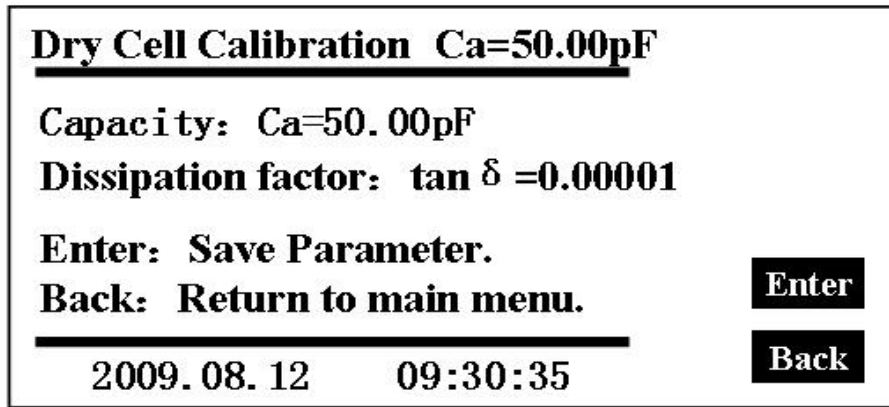

Fig.6-2

①Heating up----The test cell is heated up to the preset test temperature. Because the temperature on the capacitance and dielectric dissipation factor of test cell full of air with no apparent effect, so you can press "OK" key in the current room temperature to test.

②Boosting----On reaching the required test temperature, or after pressing "OK" key in the heating process, it is automatically transferred to boost state, with voltage value increasing and adjustment. When the voltage reaches a preset voltage value, or in the process of boosting press "OK" key, the instrument will stop boosting, and enter the test status.

③Calibration results----After test cell calibration is end, the apparatus automatically displays the calibration results, as shown in figure 7.

**Figure 7****5. Automatic measurement**

Remove the inner electrode from the outer electrode, and then take measured oil samples 40ml before entering the automatic measurement. Align the locating slot of inner electrode with the positioning key of outer electrode and put the inner electrode into the outer electrode. And also connect the test cable and temperature probe cable.

Press “Automatic measurement” key, and go to the auto-measuring screen in Figure 8.

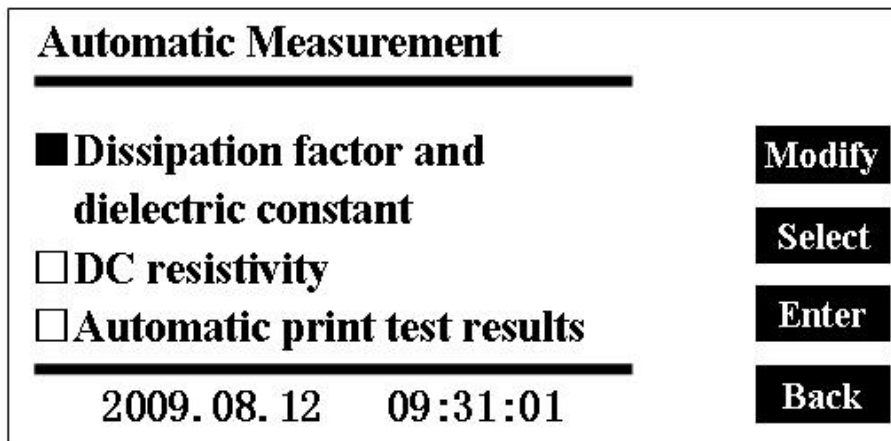
**Figure 8**

As shown in the figure above, there are three options. Press the “Select” button, the cursor cycles in beating three choices. Press the “Modify” button, to determine  $\sqrt$  or  $\times$  at the cursor. After you finish selecting items, please click “Enter” button, the instrument automatically enters the auto-measuring screen as shown in Figure 9. Press “Back” key, and return to the main menu.

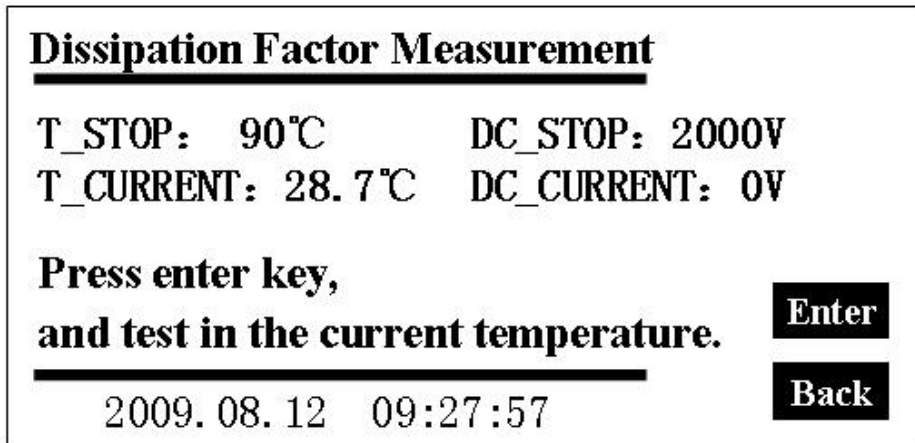

Figure 9

①Heating up---- The test cell is heated up to the preset test temperature. Because the temperature on quality properties of insulating oils have a very big impact, we should test the oil under the preset temperature, of course, we can also press “OK” button to do the test at room temperature.

②Boosting----On reaching the required test temperature, or after pressing “Enter” key in the heating process, it is automatically transferred to boost state, with voltage value increasing and adjustment. When the voltage reaches a preset voltage value, or in the process of boosting press "Enter" key, the instrument will stop boosting, and enter the test status.

③Test results----After the test, the screen automatically displays the test results, as shown in Figure 10. If you previously selected the automatic printing, the printer automatically prints test results. If you do not select automatic printing, press the “Print” button, the printer starts printing the test results displayed. Press “Back” key and return to the main menu.

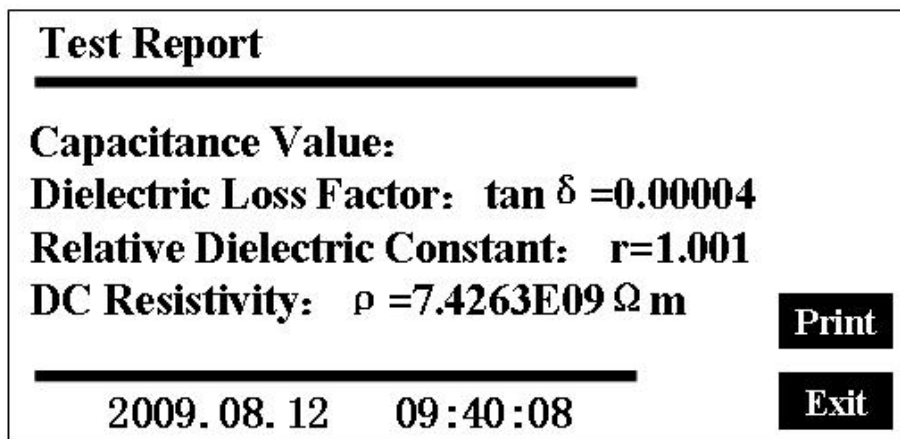
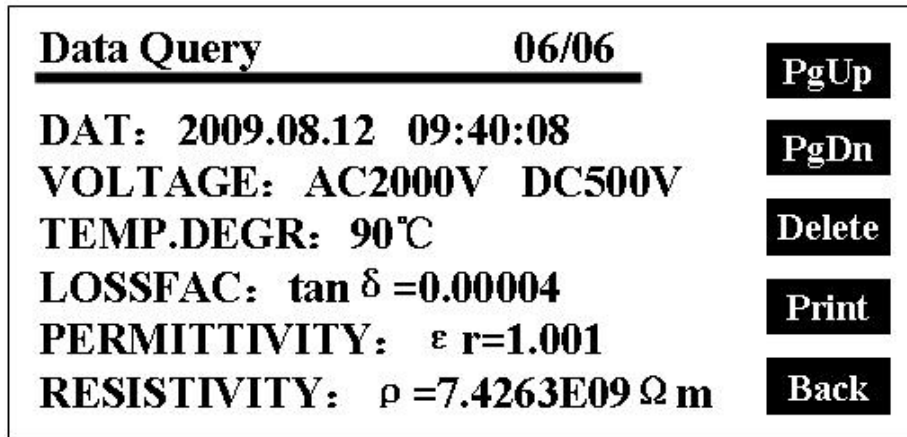

Figure 10

6.Data query

Press the “Data query” key, and go to the data query screen in Figure 11.

**Figure 11**

The instrument showed the total number of pages, and the current number of pages, save up to 99 pages. Press the “Page Up” and “Page Down” button, and you can make the page up and down. Press the “Delete” key, you can delete the data of the currently displayed page. Press the “Print” key, and you can print the current page of data. Press “Back” key and return to the main menu.

#### 7. Time settings

Press “time setting” button, and then enter the time setting screen shown in Figure 12.

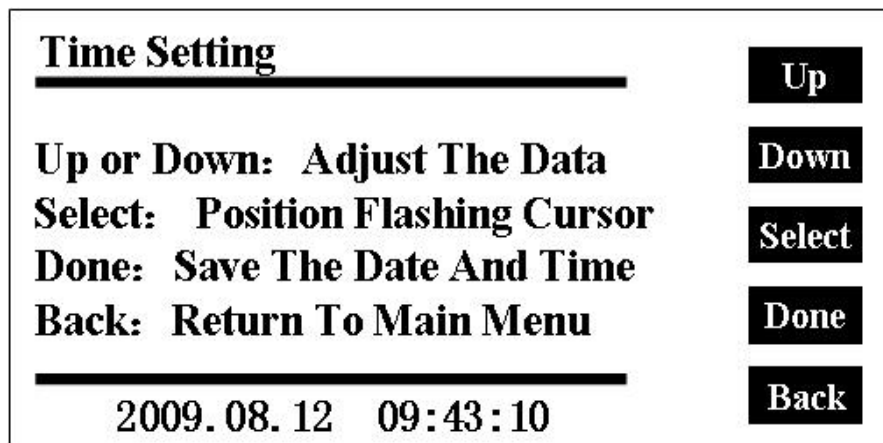
**Figure 12**

Press the “select” key to move the flashing cursor. Click “increase” and “decrease” keys to adjust the data. Press “OK” to finish modifying operations. Press the “exit” button to return to the main menu.

## VII. Instrument Verification

In the main menu interface, as shown in Figure 13, click “test conditions” into the interface as shown in Figure 14.

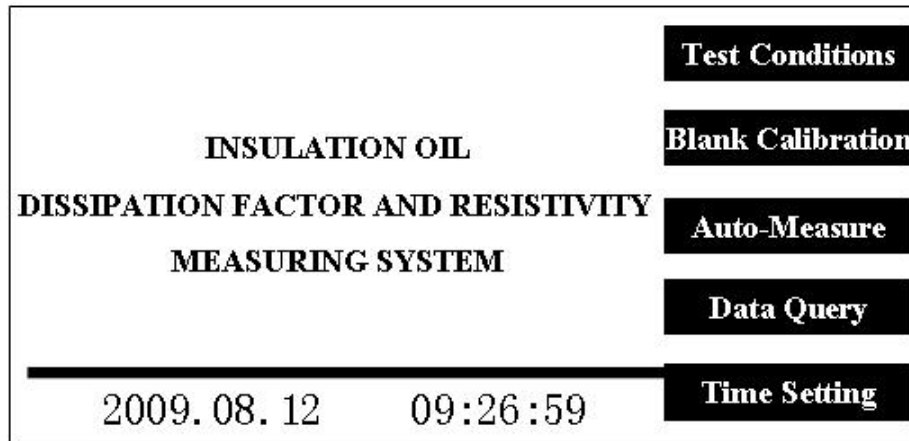

Figure 13

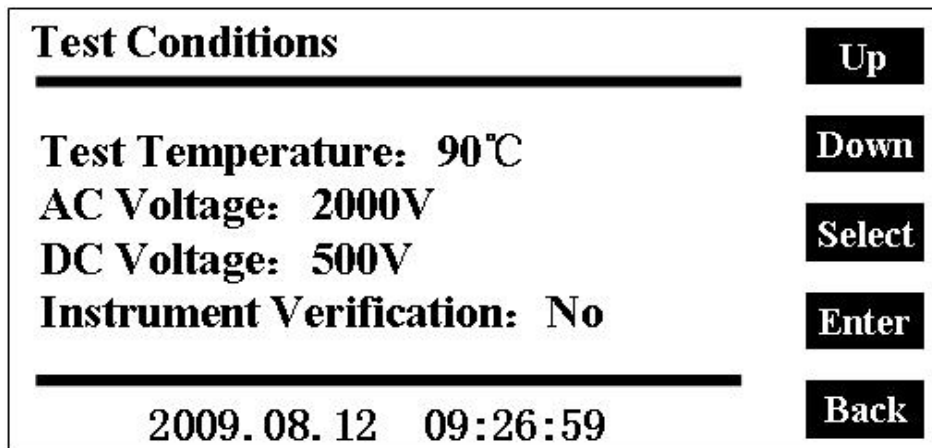

Figure 14

Press the "select" button, move the cursor to the instrument calibration, automatically select "Yes" and press "OK" button, enter the interface shown in Figure 15.



Figure 15

Correctly connect the standard. As shown in Figure 15, if you want to verify dielectric loss factor, please click the "LOSS" button. If checking the resistance value, please press the "RES" button. Press "Back" button to return to the main menu.

In the calibration process, the instrument can be operated with lid opening, but we



must be ware of electric shock.

The screen automatically displays the validation results, as shown in Figure 16, 17. Record the check results, and convert the gear of the standard, then press the “dielectric loss” key or the “resistance” button, and continue to the verification of the standard’s next gear.

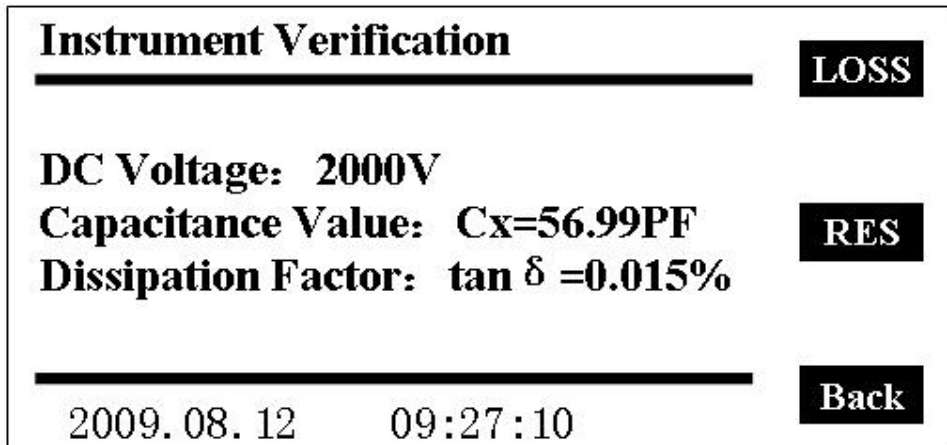

Figure 16

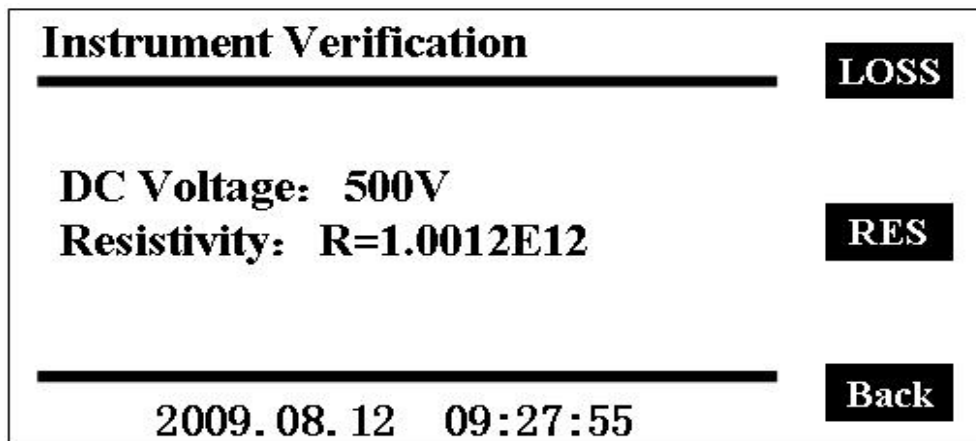

Figure 17

## VIII.Introduction To The Test Cell

1. Test cell structure

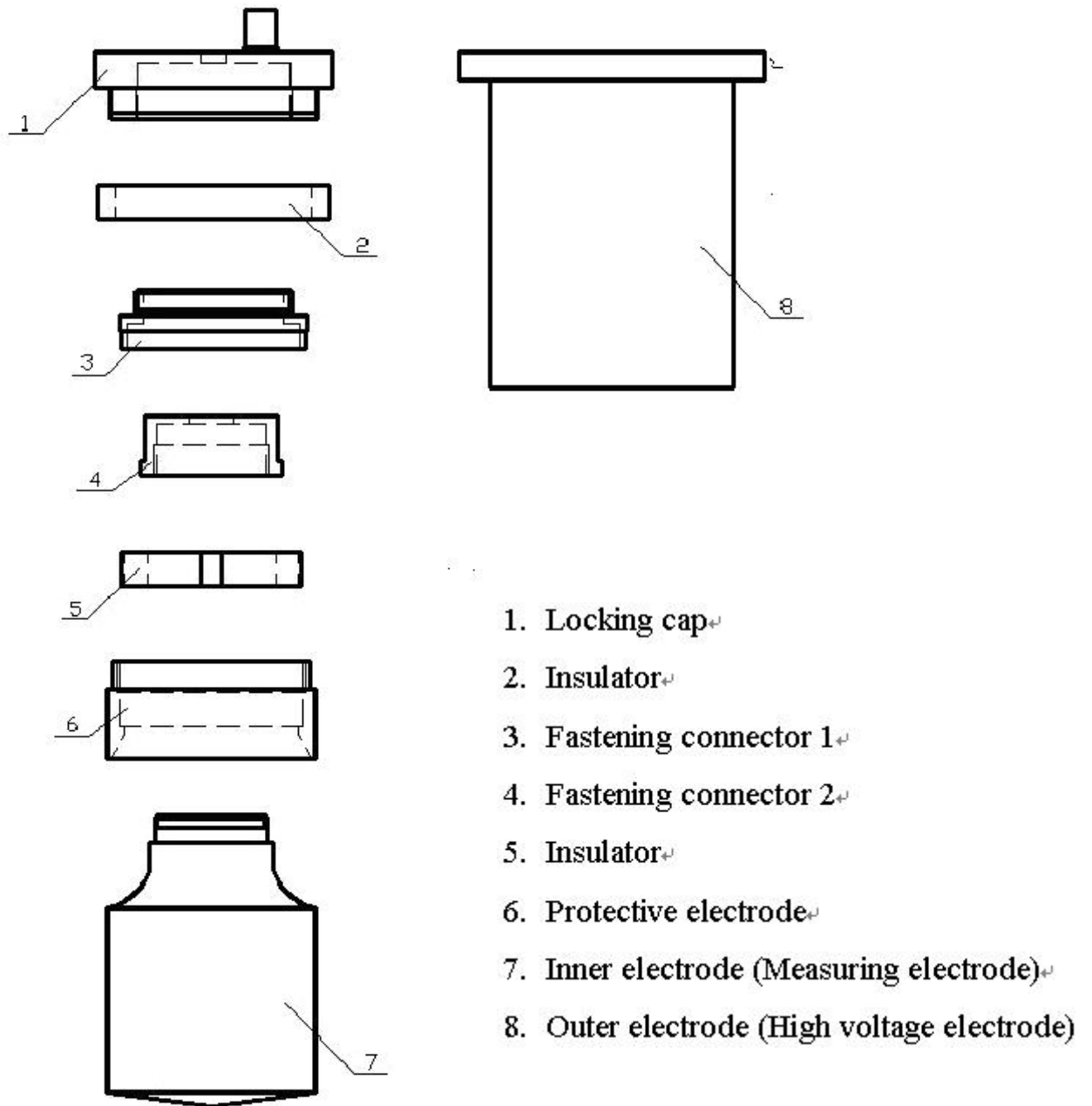
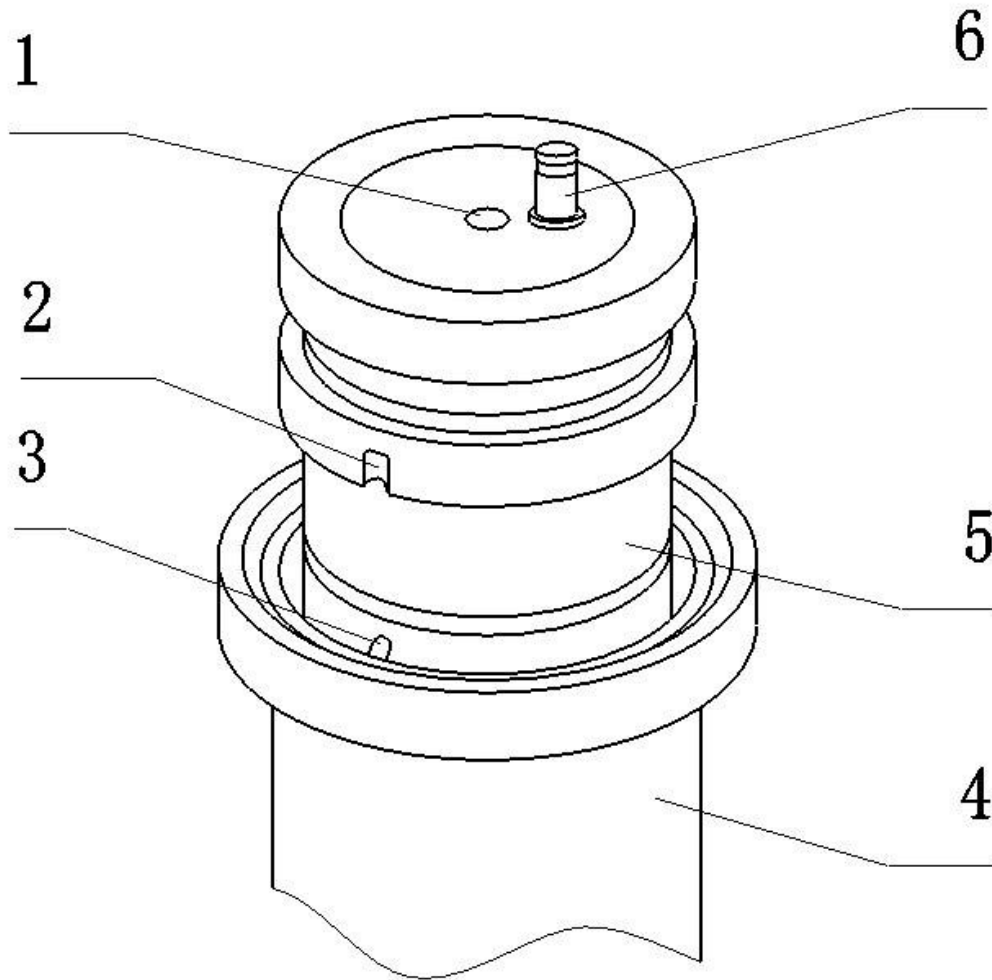

Fig.19 Exploded view of Test Cell



1. Temperature measurement hole
2. Locating slot of inner electrode
3. Positioning column of outer electrode
4. Outer electrode
5. Inner electrode
6. Measured hole

**Fig.20 Assembly drawing of Test Cell**

The parts from 1 to 7 in the figure assembled at the factory are generalized as “inner electrode”. Take the oil cup apart according to section 4, only when the need to dismantle and clean it.

## 2. Technical standards for test cell

The test cell is 3-electrode guard ring cell in accordance with the national standard of GB/T5654-2007, with electrode gap between 2mm, can eliminate the effect of stray capacitance and reducing leakage on the dielectric loss test results.

(1) Electrode gap 2mm

(2) Empty cell capacitance  $60 \pm 5 \text{PF}$



- (3) Maximum test voltage (power frequency) 2000V
- (4) Empty cell dissipation factor  $\tan \delta < 1 \times 10^{-4}$
- (5) Sample capacity approx. 40ml
- (6) Electrode material high-grade steel
- (7) Volume 70mm (D) × 120mm (H)

### 3. Dismantling and assembling the test cell.

(1) Assembling the test cell: Place the test cell smoothly into the instrument's heating furnace, and guarantee the test cell of good contact with the heater on the bottom, so that the test cell has good electrical contact and heat exposure. After loading, the test cable and temperature probe should be installed, the test line is inserted and screwed to the test electrodes socket and the temperature probe is inserted into the inner electrode.

(2) Remove the test cell: After you remove the test line and a temperature probe, remove the test cell up directly.

### 4. Dismantle test cell electrode

Loosen the fixed button ④ and carefully withdraw the measuring electrode; Similarly, Place the measuring electrode and tighten the fixed button.

**Attention:** The test cell consists of precision mechanical parts. All parts should therefore be treated with greatest care. In particular, the highly polished internal measuring electrode must not suffer damage of any kind.

### 5. Fill the test cell with test medium **slowly and continuously**.

Withdraw the inner electrode, and filling the test cell with test medium (40ml). Do not clip into the bubbles as possible in the test medium. Still more than 15 minutes, exhausts air bubbles before test.

### 6. Cleaning the test cell

Because of insulating oil on very small pollution are extremely sensitive response, the test cell should be cleaned before measuring, this step is very important. Therefore we must be accordance with the method described below in strict.

#### **Method 1:**

- (1) Dismantle the test cell electrode completely.
- (2) Wipe it with a neutral SOAP or detergent cleaning. The abrasive grains and grinding action should not damage the surface of the electrode.
- (3) Clean the electrode with clear water several times.
- (4) Soak the parts with water-free alcohol.
- (5) Wipe all the parts with clean, fluff-free cloth, and place the parts in a clean container after cleaning the test cell and do not make the surface dust and moisture contamination.
- (6) Place all the parts in an oven at a temperature between 105 and 110 deg, and dry them.



Sometimes due to more samples, so the samples are often tested one by one during the test. Electrode cleaning can be simplified. Specific practices are as follows:

- (1) Close the instrument, take out the entire test cell from the heater, and remove the electrode from the test cell at the same time.
- (2) Pour oil in the test cell into the waste oil container, flush the test cell with new oil several times.
- (3) Fill the test cell with new oil.
- (4) Flush the inner electrode in a few times with new oil, and mount it in the test cell.

The method of washing oil to oil can significantly improve the speed of measurement, but if the test medium is particularly dirty, or when you have not used the instrument for a long time, you should use the first method.

**Method 2:**

- (1) Dismantle the test cell (See sketch of test cell).
- (2) Clean all parts with chemical pure oil petroleum ether and benzene thoroughly.
- (3) Use acetone cleaning the test cell again, and then with a neutral detergent rinse clean.
- (4) Boil 5 minutes with 5% sodium phosphate solution of distilled water, and then use distilled water to wash a few times.
- (5) Clean all the parts with distilled water several times.
- (6) Place all the parts in an oven at a temperature between 105 and 110 deg, Dry them for 60 to 90 minutes.
- (7) Assemble them when the temperature falls below normal temperature after cleaning all the parts.

**Method 3:** Ultrasonic cleaning methods

- (1) Dismantle the test cell.
- (2) Wash all parts with solvents.
- (3) Shake all parts for 20 minutes in an ultrasonic cleaner with soapy water. Withdraw the parts, clean them with tap water and distilled water, and shake for 20 minutes in distilled water.

**Method 4:** Solvent cleaning method

- (1) Dismantle the test cell.
- (2) Wash all parts with solvents, and change the solvents.
- (3) Wash all parts with the acetone first, then tap water. Then clean them with distilled water.
- (4) Dry the parts 60~90 minutes in the oven at temperature of 105~110°C.

When testing a group of similar liquid samples but not used, as long as the last test sample has better performance than the specified value of the measuring, we can use the



same test cell without intermediate washing. If the performance of the tested sample is inferior to the measuring sample, the test cell must be cleaned before you do the next test.

## IX. Common Problems

1. The screen displays “short circuit of electrode cup”.

A: First check whether the locating slot of external electrode is alignment with the internal electrode and if the internal electrode is correctly inserted into the locating slot.

2. The screen displays “Please do ‘Test Cell Calibration’.”

A: Test cell calibration is needed when the capacitance value of test cell is not in the range of  $60 \pm 5 \text{pF}$ .

① The electric discharge phenomena will appear if the internal or external electrode did not load properly or the internal electrode is not assembled well.

② The oil cup is needed cleaning if it is not clean or there are impurities between the inner and outer electrodes.

3. The instrument returns to the main interface after the buzzer makes a buzzing sound for five times.

A: ① Check if the capacitance value of test cell is within the range of  $60 \pm 5 \text{pF}$ . ② Check if the oil cup is loaded well or the electric discharge phenomena appears.

4. When testing DC resistivity, the time for 60 seconds of electrochemical process makes no changes.

A: Check if the instrument’s clock is in operation, and adjust the clock.

5. What is to be done, when the digit display of voltage parameter to be set is non-zero?

A: Press the [down] key to make the voltage parameter to be set becoming the smallest, and then click the [up] key to adjust it to zero.

## X. Packing List

No.	Item	Qty
1	Main engine	1
2	Oil Cup	1
3	50ml measuring cylinder	1
4	Wrench	1
5	Power line	1



<b>6</b>	Fuse pipe	2
<b>7</b>	Temperature probe	1
<b>8</b>	Dedicated test cable	1
<b>9</b>	Print paper	2